

*Technical filter*  
**ACO Stormclean TF**



## What is a technical filter?

Technical filters are used to remove substances including mineral oil, heavy metals (copper, zinc and lead), and phosphor which are added to rainwater by different types of traffic and industrial processes.

In rainwater, most heavy metals attach themselves to 'suspended solids' (SS) - **sludge particles which are smaller than 63 microns (0.063 mm) in size and which can not be removed via gravity separation.**

As a result, an alternative to gravity separation is required - the use of a technical filter.

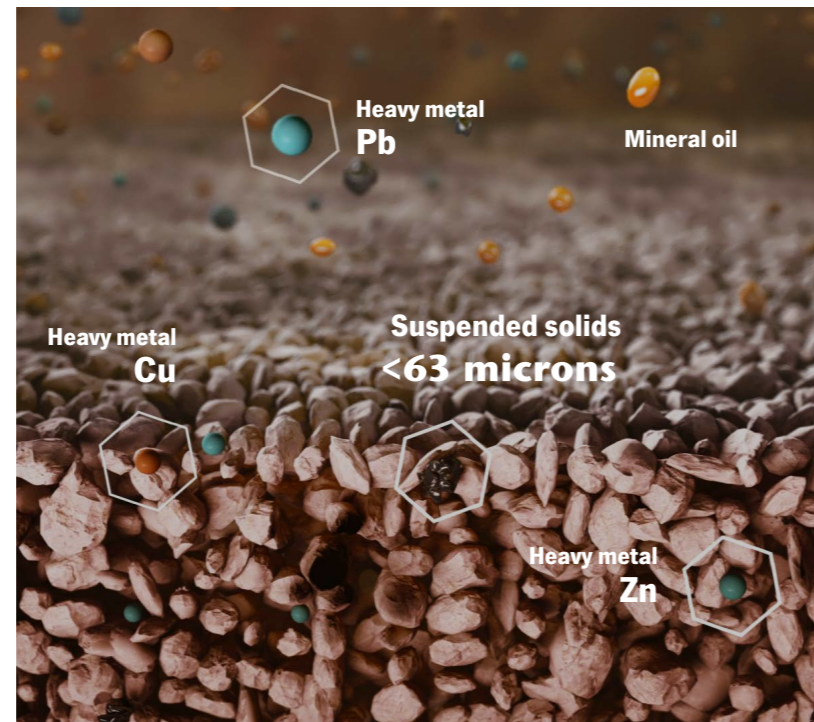

## The Solution

**ACO Stormclean TF cleans rainwater from surfaces that are frequently used by all types of vehicles including heavy goods traffic.** The filter removes rainwater contaminants including mineral oils and heavy metals collected from **traffic areas**, and copper and zinc collected from **roofs**. ACO Stormclean TF uses a highly reactive filter material to adsorb these substances and is particularly effective at removing TSSs - suspended solids with a particle size of less than 63 microns. TSSs are captured by the filter material to protect the groundwater from contamination.

**ACO Stormclean TF has a tested area ratio of 1:250. This means that 1m<sup>2</sup> of filter surface cleans 250 m<sup>2</sup> of the surrounding (or surrounding) area (ÖNORM B 2506-3).**

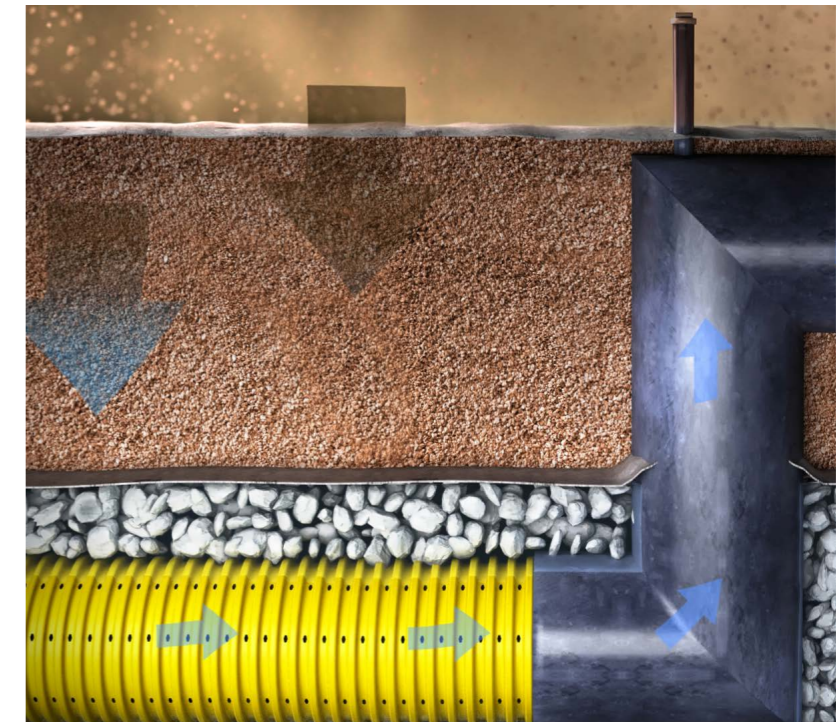

A sludge trap is an important part of the ACO Stormclean system and is required to optimise the life of the filter\*.

\*The filter lifetime decreases without the sludge trap.

## The Impact of Pollutants



**Air pollution**



**Exhaust fumes**



**Vehicle tyres and brakes**



**Metal roofs**

### Where do surface pollutants come from?

- Industrial production
- Wear of tyres and brakes
- Vehicle exhaust fumes
- Oil leaks from cars
- Metal roofs

### Negative effects of water pollution

- Groundwater pollution
- Pollution of watercourses and contamination of field crops
- The appearance of pollutants in organic organisms

**IMPACT ON HUMAN HEALTH**

ACO Stormclean TF is suitable as a **pre-treatment for Stormbrixx** infiltration or as a cleaning element for a variety of applications where a high level of cleaning is required.

## Norm

The filter material has an area ratio of 1:250 and is fully tested to Austrian **ÖNORM B 2506-3**.

This means that 1 m<sup>2</sup> of the filter surface cleans 250 m<sup>2</sup> of the surrounding area (240 l/s\*ha).

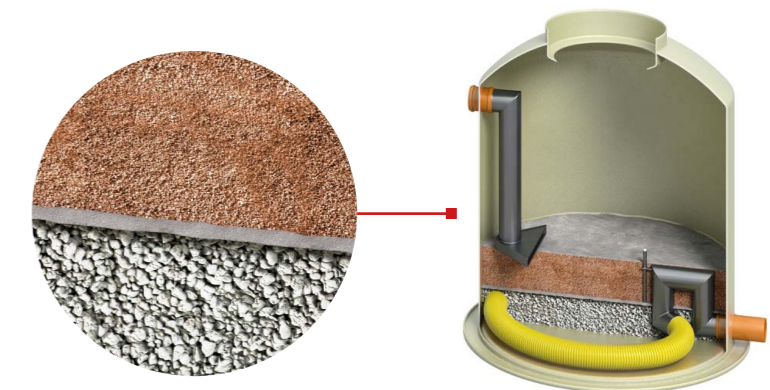

For more detailed information please contact Customer service / Technical support ACO Tábor

**Branislav Greguš**  
bgregus@aco.cz



**Pavel Břešťák**  
pbrestak@aco.cz





**Applications – system chain**

**LOGISTICS AREA**

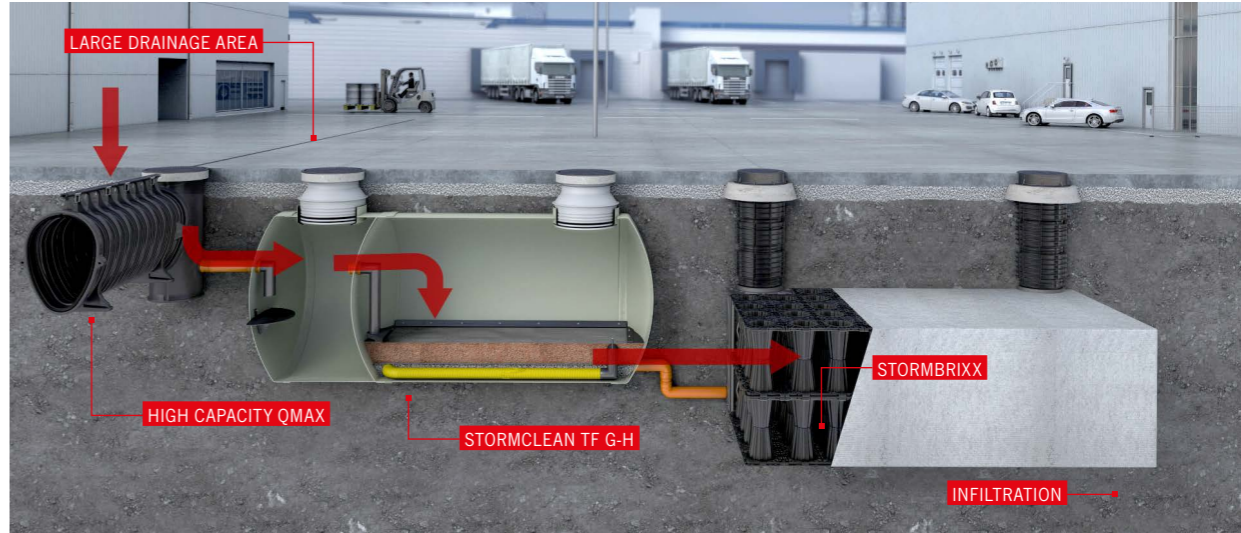

**CAR PARKS**

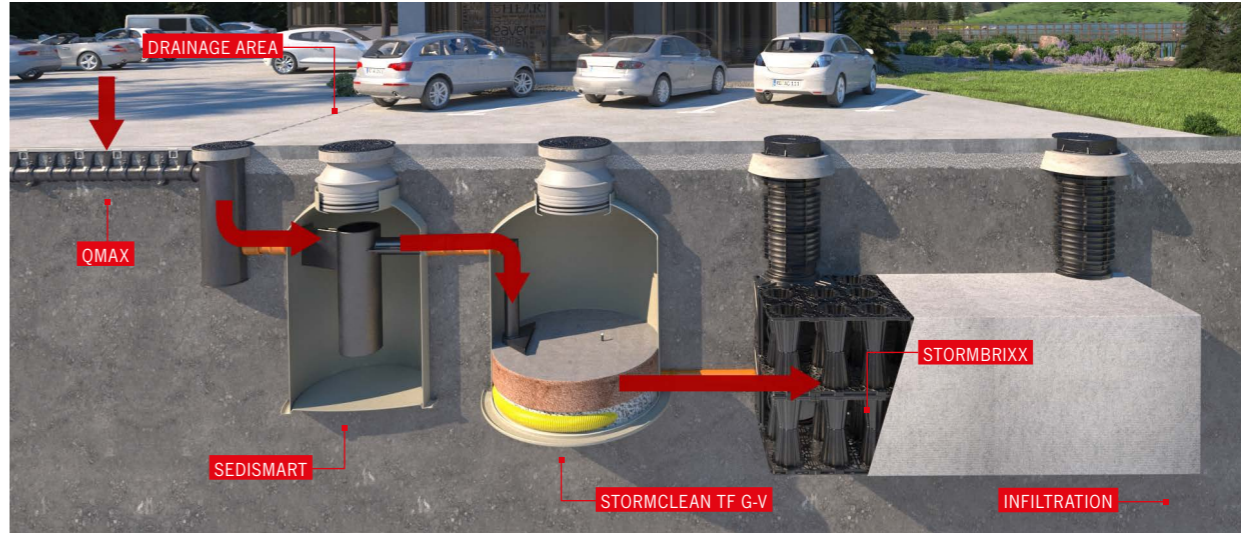

**WATER RECYCLING\***

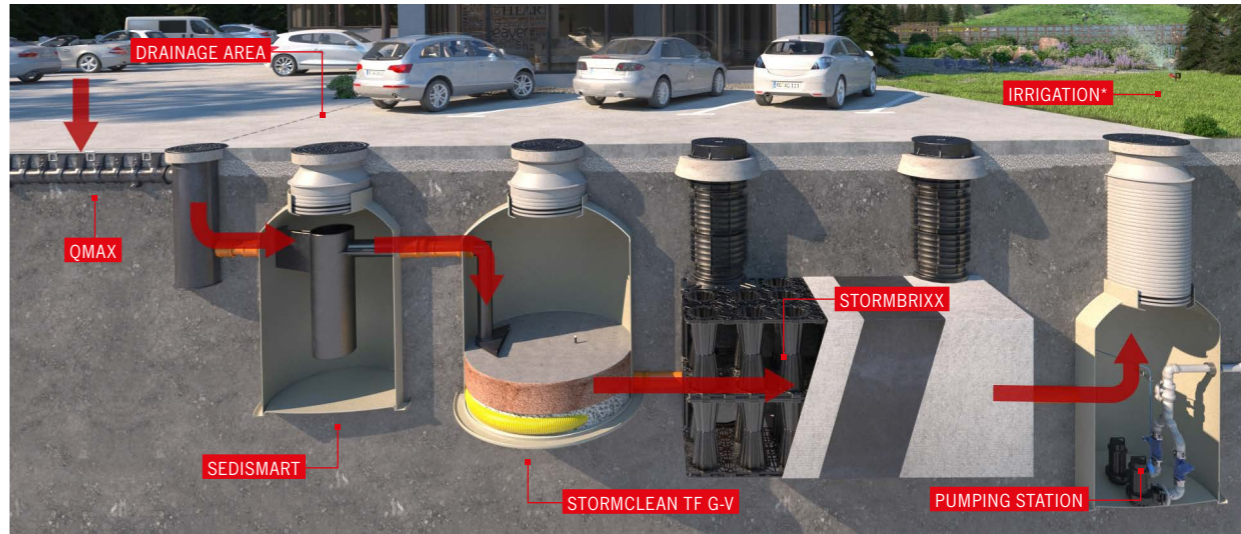

With ACO Stormclean TF, a filter area of just 4 m<sup>2</sup> is required to decontaminate an area measuring 1 000 m<sup>2</sup>.  
 Specification of the filter in conjunction with GRP containers ensures that the system is suitable for use on surfaces which are used for variety of applications including frequent heavy goods traffic.

**Product range**

ACO Stormclean TF 600 G-V	ACO Stormclean TF 850 G-V	ACO Stormclean TF 1 000 G-H	ACO Stormclean TF 1 300 G-H
<b>630 m<sup>2</sup></b>	<b>860 m<sup>2</sup></b>	<b>1 010 m<sup>2</sup></b>	<b>1 300 m<sup>2</sup></b>

\* It depends on the required water quality according to local regulations

## ACO Stormclean TF G-V

ACO Stormclean TF G-V uses a vertical tank construction and includes a sampling unit. A sludge trap is not included in the ACO Stormclean vertical storage tank. Specifiers can choose between a standard sludge tank or a 'Sedismart' tank which delivers higher sedimentation efficiency and, as a result, extends filter life.

### Benefits

- Simultaneous water cleaning via the removal of mineral oils, heavy metals and suspended solids
- Technical filter already pre-assembled! **Just plug it in.**
- Optimal accessibility for maintenance, cleaning and disposal
- As lightweight as plastic, as strong as concrete
- Tested filter life of upto four years\* (replaceable for the new material\*\*)
- Sample unit included

\* Filter life may vary depending on the type of pollution being filtered

\*\* available with specific item number

Note:

Article number of Stormclean does not include the filter media. Please add also particular article number of filter replacement (last page of this document).

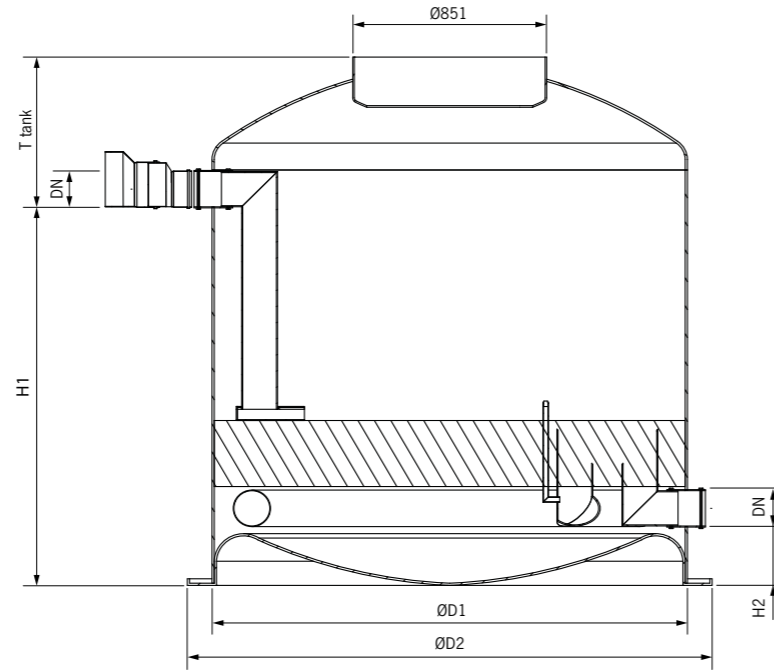

## ACO Stormclean TF G-H

ACO Stormclean TF G-H uses a horizontal tank construction and contains both a sludge trap and a sampling unit. Thanks to the horizontal construction, it is possible to modify the length of the whole tank and to configure it precisely to meet the drainage requirements of any given surface area. In addition to the two standard specifications, ACO Stormclean TF G-H can be tailored to meet the needs of individual applications.

### Benefits

- Simultaneous water cleaning via the removal of mineral oils, heavy metals and suspended solids
- Technical filter already pre-assembled! **Just plug it in.**
- 3in1 solution – sludge trap, technical filter, sampling unit in one tank
- Tailored solutions available to meet individual project requirements
- Optimal accessibility for maintenance, cleaning and disposal
- As lightweight as plastic, as strong as concrete
- Filter product life of up to four years\* (replaceable for the new material\*\*)

\* Filter life may vary depending on the type of pollution being filtered

\*\* available with specific item number

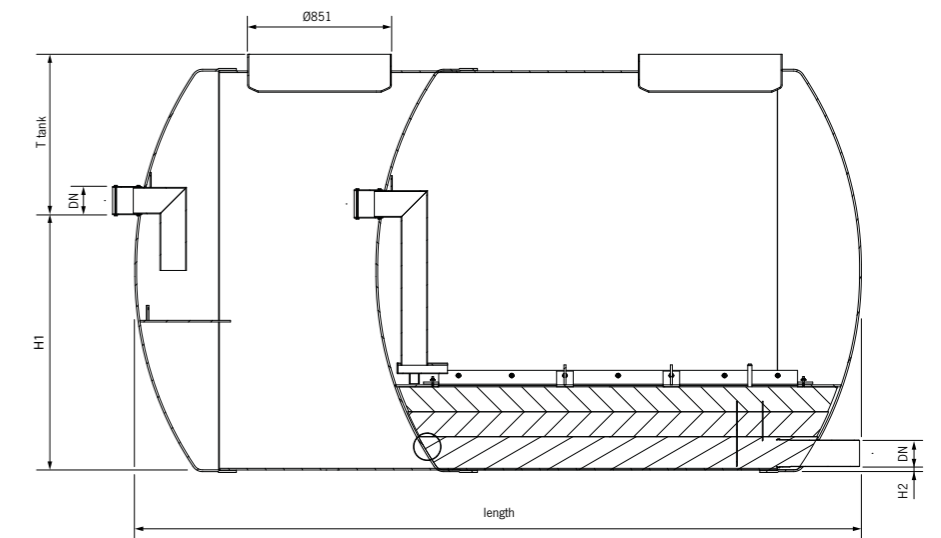

Item	In/Out let DN	Drained surface [m2]	Max. water flow [l/s]	Position	Sludge trap volume [l]	Filter tank volume [l]	volume filter [m3]	weight filter material [kg]	art.
TF 600 G-V	DN160	630	15	Vertical	0 (2620)*	3760	0,764	451	12920.01
TF 850 G-V	DN160	860	20	Vertical	0 (3271)**	5420	1,04	614	12921.01

Dimension									
Item	art.	H1 [mm]	H2 [mm]	ØD1 [mm]	ØD2 [mm]	T tank [mm]	length total tank - sludge trap + filter [mm]	Tank height [mm]	Total weight [kg]
TF 600 G-V	12920.01	1520	70	1800	2040	680	4460	2200	1530
TF 850 G-V	12921.01	1720	270	2100	2340	680	5110	2400	2544

\*Recommended sludge trap with a volume of 2,000 liters (Item No. 12816.01).

\*\* Recommended sludge trap with a volume of 3,000 liters (Item No. 12817.01).

Item	In/Out let DN	Drained surface [m2]	Max. water flow [l/s]	Position	Sludge trap [l]	Filter tank volume [l]	volume filter [m3]	weight filter material [kg]	art.
TF1000 G-H	DN250	1010	25	Horizontal	4283	7600	1,21	714	12929.01
TF1300 G-H	DN250	1300	31	Horizontal	5054	9710	1,56	920	12930.01

Dimension									
Item	art.	H1 [mm]	H2 [mm]	ØD2 [mm]	T tank [mm]	length total tank - sludge trap + filter [mm]	Tank height [mm]	Total weight [kg]	
TF1000 G-H	12929.01	1540	20	2400	960	4370	2500	2228	
TF1300 G-H	12930.01	1540	20	2400	960	5470	2500	2689	

Note:

Article number of Stormclean does not include the filter media. Please add also particular article number of filter replacement (last page of this document).

## Stormclean - filter replacement

Art. n.	Product	Package
12924.01	Filter set TF 600 G-V	New filter material 451 kg, geotextile
12925.01	Filter set TF 850 G-V	New filter material 614 kg, geotextile
12926.01	Filter set TF 1000 G-H	New filter material 714 kg, geotextile
12927.01	Filter set TF 1300 G-H	New filter material 920 kg, geotextile
12928.01	Filter material bag	New filter material 20 kg

## Stormclean - water quality performance

Mentioned values are based on testing according to ÖNORM 2506-3

Test	Requirements according to ÖNORM B 2506-3	Paved areas Stormclean TF test results
Infiltration rate	> 0,00001 m/s	<b>0,006 m/s</b>
Retention of suspended solids	> 80 %	<b>83,4 %</b>
Retention of heavy metals	Pb < 9 µg/l *	<b>&lt; 9 µg/l</b>
	Cu > 80 %	<b>98,4 %</b>
	Zn > 50 %	<b>99,9 %</b>
Heavy metals remobilization	PB < 9 µg/l	<b>PB &lt; 9 µg/l</b>
	Cu < 50 µg/l	<b>&lt; 5 µg/l</b>
	Zn < 500 µg/l	<b>63 µg/l</b>
Retention of mineral oil	> 95 %	<b>&gt; 99 % (&gt; 0,05mg/l)</b>

\* Output concentration in testing sample

## Testing conditions

### Retention of mineral oil

The testing sample comprises a standard mineral oil. Testing is conducted over a 20 minute period and four samples are taken in total - one every five minutes. To simulate the average amount of contamination which would need to be removed during a three month period, 3.5 g of oil and 350 l of water are used during the 20 minute testing period. Test results show that, after cleaning, residual contamination was measured at levels below 1% (less than 0.035 g of oil per 350 l of water).

### Retention of suspended solids

Testing is undertaken using 84 g of the silicon powder mix in 350 l of water. With 83.4 % filtration efficiency, 13.9 g

of suspended solid remains in 350 l of water after filtration which equates to 0.039 g of suspended solids per litre.

### Retention of heavy metals - 1

Filter material is polluted by Pb:50 µg/l, Cu:100 µg/l, Zn:400 µg/l in 42 l of water. Output concentration of Pb: < 9 µg/l, retention in filter material of Cu: > 80 % and Zn: > 50 %.

### Retention of heavy metals - 2

Retention of heavy metals test 2 proceed after test 1. Filter material is polluted by Pb:200 µg/l, Cu:400 µg/l, Zn:1600 µg/l in 84 l of water. Four random samples are taken in outlet, each flowing 20 % of the total amount of water. When the last sample is taken, the remainder

of the water is captured as a mixed sample and subjected to analysis.

### Heavy metals remobilization

Run immediately after the retention of heavy metals test 2, this test uses a sample of saline solution (5 g NaCl per litre) in a total volume of 42 litres of water. Filter material is flushed by the saline solution (simulation of operating during winter time) and measured. Concentration of Cu cannot be higher than 50 µg/l and Zn cannot be higher than 500 µg/l. As much of the pollutant as possible should remain in the filter material. This means that the filter material is perfect for the adsorption of pollutants but it cannot be reused.

